

# OWNERS MANUAL

**Model No.  
45-02113**

**CAUTION:**  
Read Rules for  
Safe Operation  
and Instructions  
Carefully



## 125 LB. TOW BROADCAST SPREADER

- Safety
- Assembly
- Operation
- Maintenance
- Parts

## RULES FOR SAFE OPERATION

Any power equipment can cause injury if operated improperly or if the user does not understand how to operate the equipment. Exercise caution at all times when operating equipment.

- Read the towing vehicle owners manual and towing vehicle safety rules. Know how to operate your tractor before using the broadcast spreader attachment.
- Read the chemical label instructions and cautions for handling and applying the chemicals purchased for spreading.
- Wear eye and hand protection when handling and when applying lawn or garden chemicals.
- Never operate tractor and spreader attachment without wearing substantial footwear, and do not allow anyone to ride or sit on spreader attachment frame.
- Never allow children to operate the tractor or spreader attachment, and do not allow adults to operate without proper instructions.
- Always begin with the transmission in first (low) gear and with the engine at low speed, and gradually increase speed as conditions permit. Maximum towing speed - 10 M.P.H.
- When towing broadcast spreader do not drive too close to a creek or ditch and be alert for holes and other hazards which could cause you to loose control of the broadcast spreader and tractor.
- Before operating vehicle on any grade (hill) refer to the safety rules in the vehicle owner's manual concerning safe operation on slopes. **Stay off steep slopes!**
- Follow maintenance and lubrication instructions as outlined in this manual.



LOOK FOR THIS SYMBOL TO POINT OUT IMPORTANT SAFETY PRECAUTIONS. IT MEANS -- ATTENTION! BECOME ALERT! YOUR SAFETY IS INVOLVED.

## CARTON CONTENTS

### LOOSE PARTS IN CARTON

1. Hitch Tube
2. Flow Control Arm
3. Hitch Bracket
4. Flow Control Mount Bracket
5. Braces (2)
6. Flow Control Rod
7. Wheels
8. Hopper Assembly  
Hardware Package (see page 3)

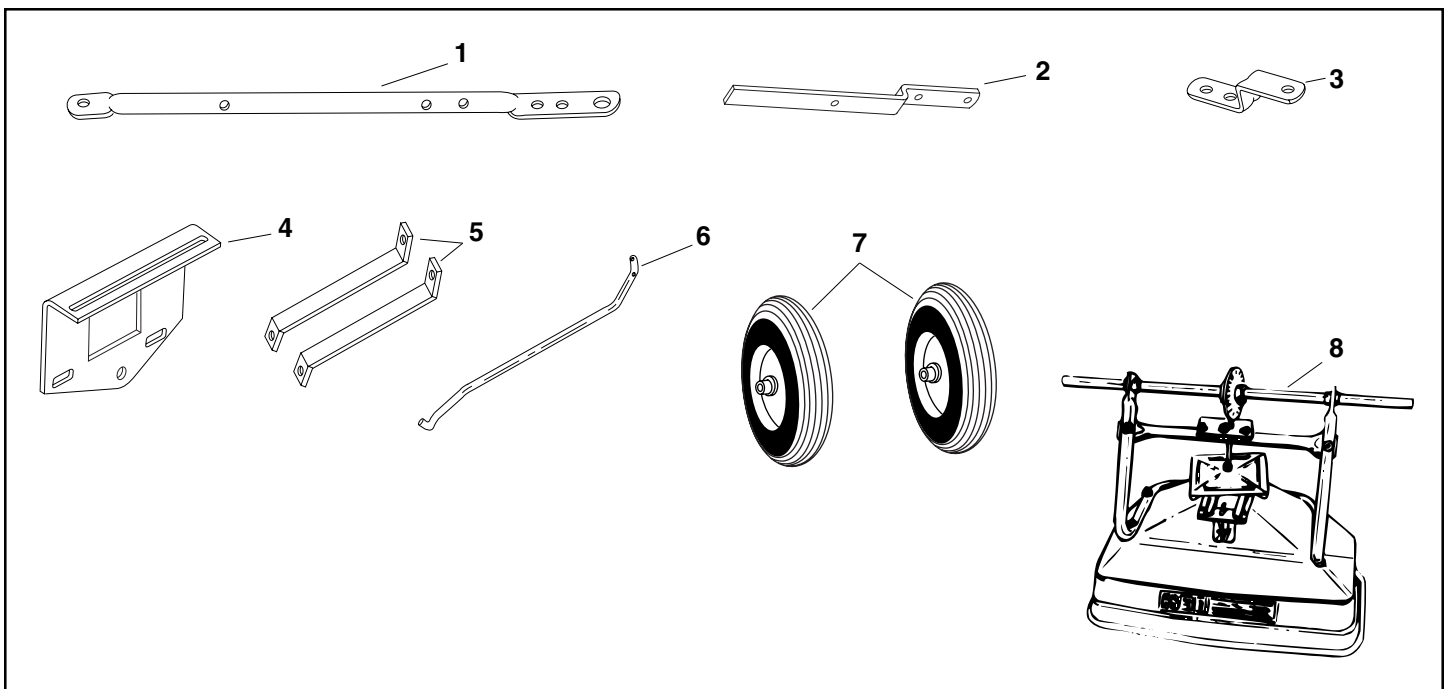

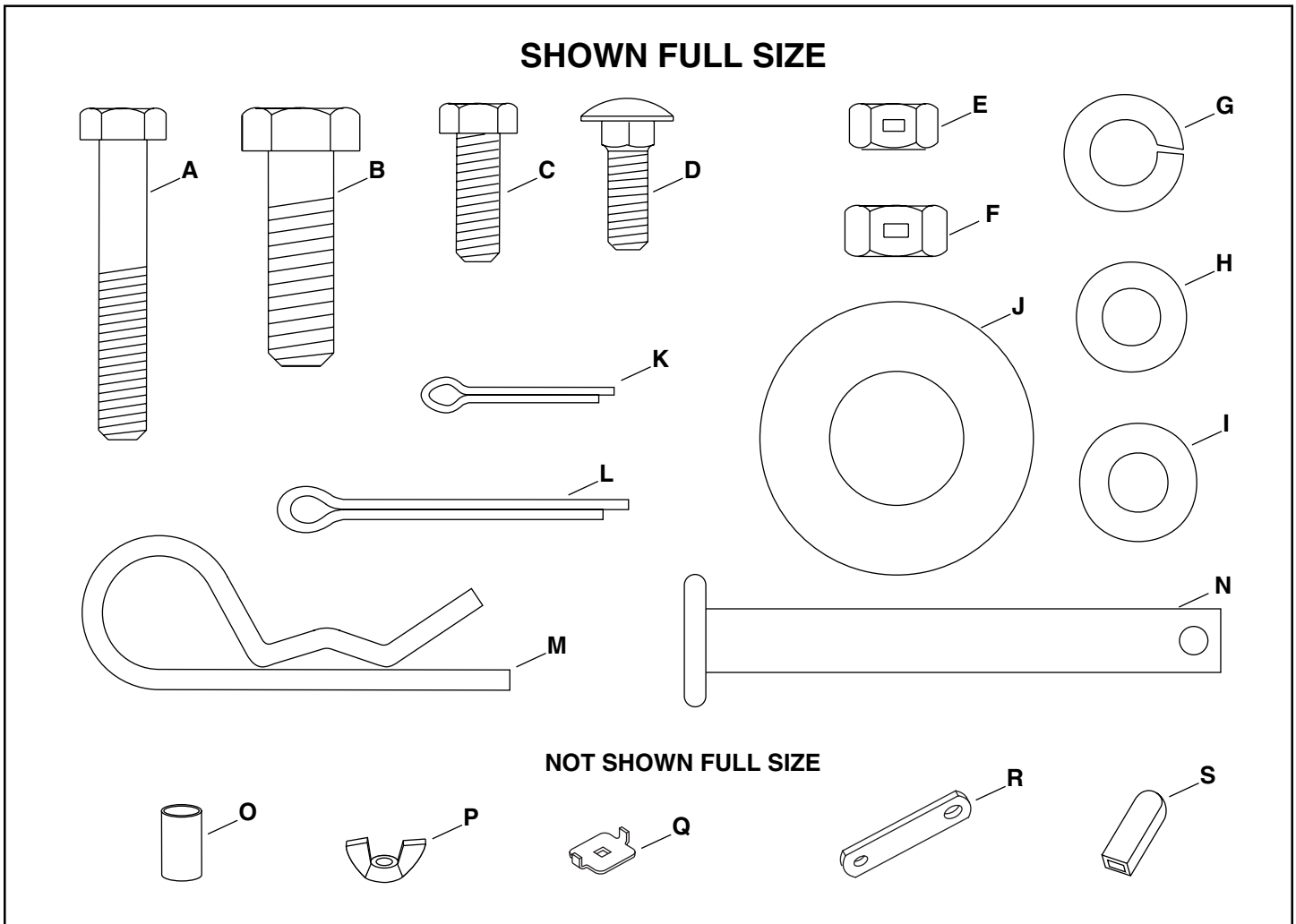

KEY	QTY.	DESCRIPTION	KEY	QTY.	DESCRIPTION
A	6	Hex Bolt, 1/4-20 x 1-3/4"	J	4	Flat Washers 1-5/8"
B	2	Hex Bolts, 3/8-16 x 1-1/4"	K	1	Cotter Pin, 3/32" x 3/4"
C	2	Hex Bolt, 1/4-20 x 3/4"	L	1	Cotter Pin, 1/8 x 1-1/2"
D	1	Carriage Bolt, 1/4-20 x 3/4"	M	1	Hair Cotter Pin, 1/8"
E	8	Hex Lock Nuts, 1/4-20 Thread	N	1	Hitch Pin
F	2	Hex Lock Nuts, 3/8-16 Thread	O	2	Spacers
G	2	Lock Washers, 3/8" I.D.	P	1	Nylon Wing Nut
H	4	Nylon Washer	Q	1	Adjustable Stop
I	8	Flat Washer, 5/16"	R	1	Flow Control Link
			S	1	Grip

## ASSEMBLY INSTRUCTIONS

### TOOLS REQUIRED FOR ASSEMBLY

- (1) Pliers
- (2) 7/16" Wrenches
- (2) 1/2" Wrenches
- (2) 9/16" Wrenches

### REMOVAL OF PARTS FROM CARTON

Remove all parts and hardware packages from the carton. Lay out all parts and hardware and identify using the illustrations on pages 2 and 3.

1. Turn the spreader upside down as shown in figure 1.

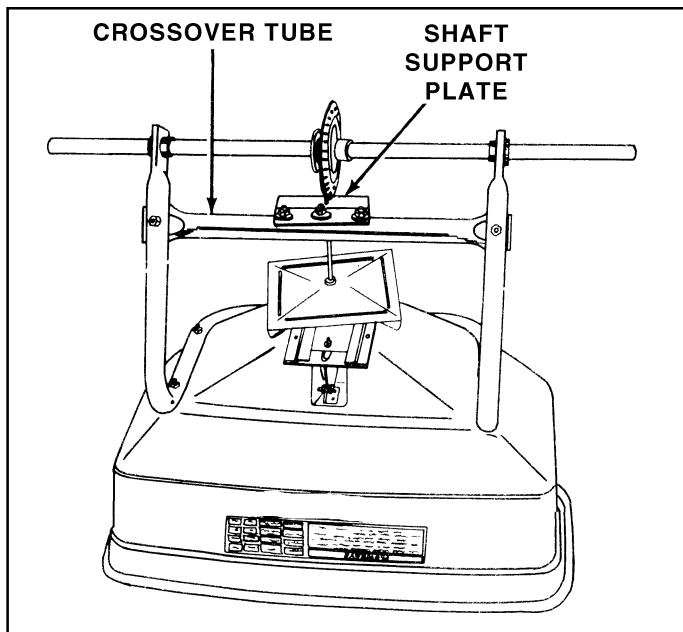

FIGURE 1

2. Assemble the two hitch braces to the inside of the hopper frame, one on each side, using two 1/4" x 1-3/4" hex bolts and two 1/4" hex lock nuts. **DO NOT TIGHTEN YET.** See figure 2.
3. Remove the lock nut from the middle bolt in the crossover tube and shaft support plate. Leave the bolt in place. See figure 2.
4. Assemble the short end of the hitch tube onto the middle bolt and secure it with the same lock nut you removed. **DO NOT TIGHTEN YET.** See figure 2.  
**IMPORTANT:** The hitch tube must attach to the side of the crossover tube opposite the shaft support plate.
5. Assemble the two hitch braces to the hitch tube using a 1/4" x 1-3/4" hex bolt and a 1/4" hex lock nut. **DO NOT TIGHTEN YET.** See figure 2.

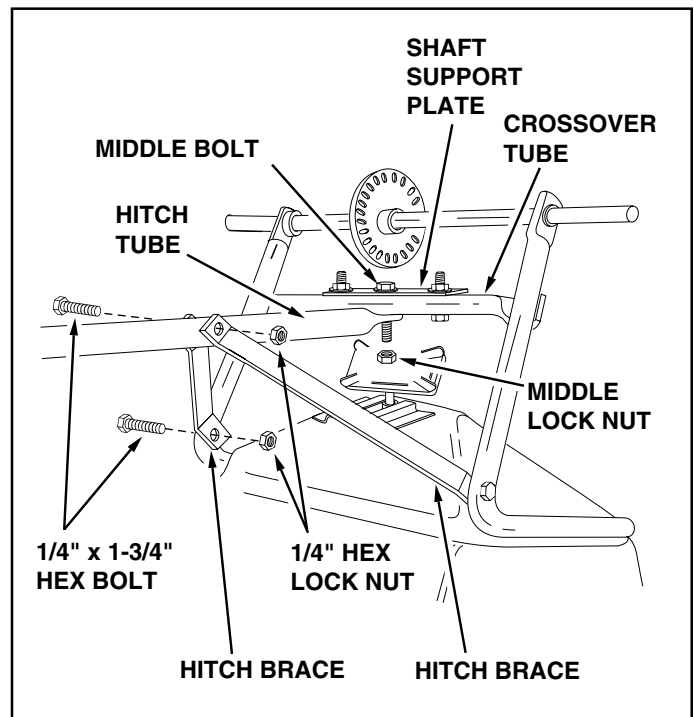

FIGURE 2

6. **Tighten** the nuts and bolts fastening the hitch braces to the hopper frame and the hitch tube, then tighten the middle lock nut fastening the hitch tube to the crossover tube. **DO NOT COLLAPSE TUBES WHEN TIGHTENING.**
7. Assemble a spacer and a 1-5/8" flat washer onto the end of the axle that has the **small hole**. See figure 3.
8. Place a wheel (air valve facing out) and then one or two 1-5/8" flat washers onto the axle. Install the 1/8" x 1-1/2" cotter pin into the axle. The wheel must spin freely. See figure 3.

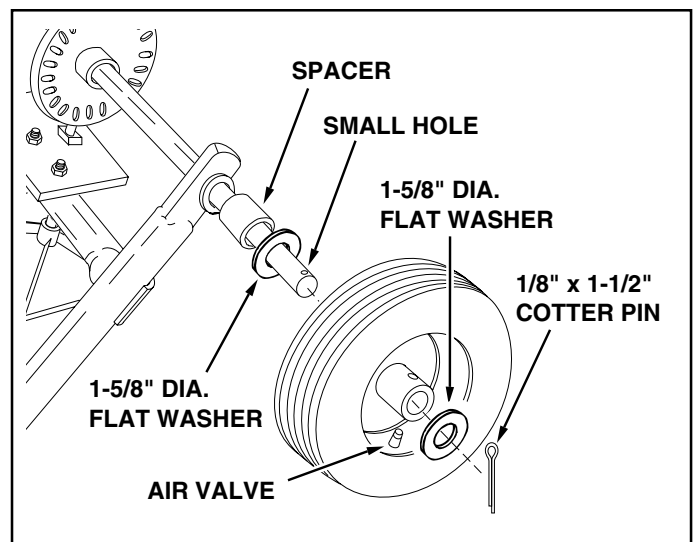

FIGURE 3

9. Assemble a spacer and a 1-5/8" flat washer onto the end of the axle that has the large hole. See figure 4.
10. Place a wheel (air valve facing out) onto the axle. Secure the wheel to the axle with a 1/4" x 1-3/4" hex bolt and a 1/4" hex lock nut. See figure 4.

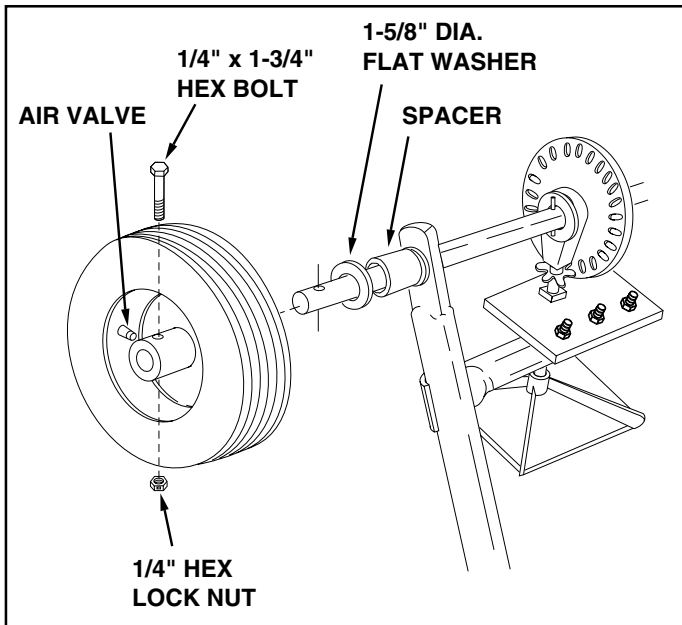

FIGURE 4

11. Turn the spreader upright on its wheels.
12. Assemble the hitch bracket to the top of the hitch tube using two 3/8" x 1-1/4" hex bolts, 3/8" lock washers and 3/8" hex lock nuts. See figure 5.
13. Assemble the hitch pin through the hitch bracket and the hitch tube and secure with the hair cotter pin. See figure 5.

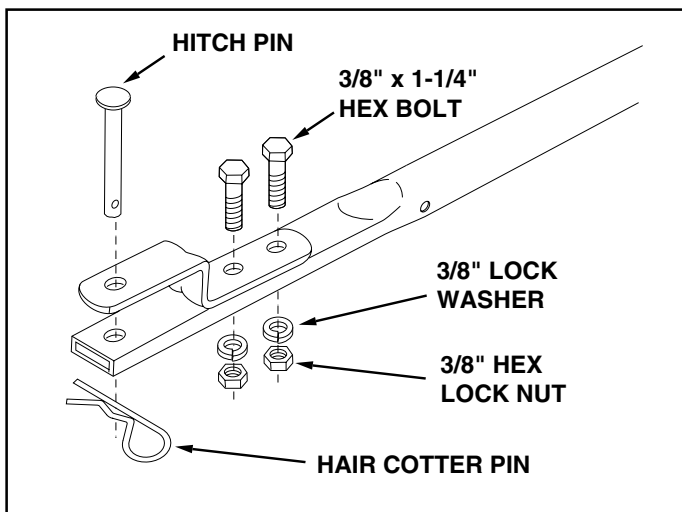

FIGURE 5

14. Assemble the flow control link (end with small hole) to the flow control arm using a 1/4" x 3/4" hex bolt, a nylon washer and a 1/4" hex lock nut. **Tighten carefully.** The flow control link should not be loose but should pivot with no more than slight resistance. See figure 6.

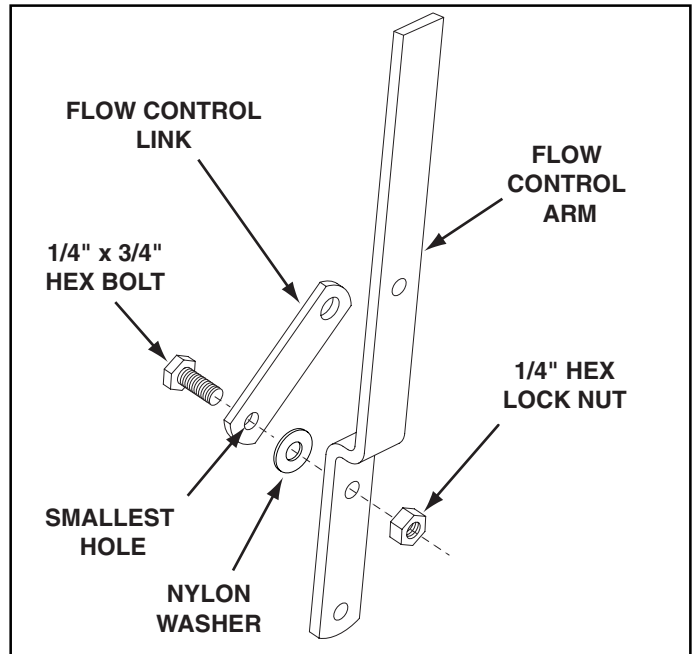

FIGURE 6

15. Assemble the flow control arm to the flow control mounting bracket using a 1/4" x 3/4" hex bolt, two nylon washers and a 1/4" hex lock nut as shown in figure 7. **Tighten carefully.** The flow control arm should pivot with a slight resistance.
16. Assemble the vinyl grip. See figure 7.

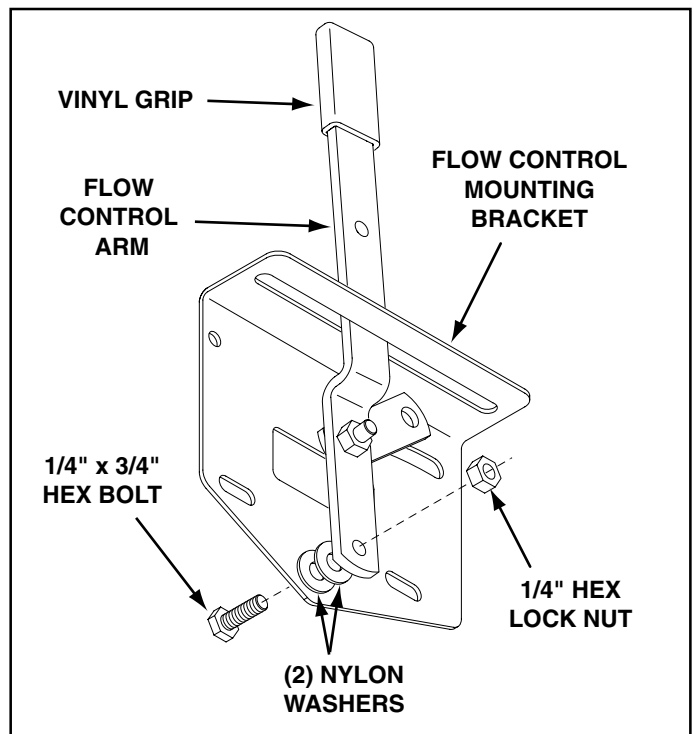

FIGURE 7

17. Place a 5/16" flat washer onto the end of the flow control rod. Insert the end of the rod through the slot in the flow control mounting bracket and through the hole in the flow control link. Secure with a 3/32" cotter pin. See figure 8.

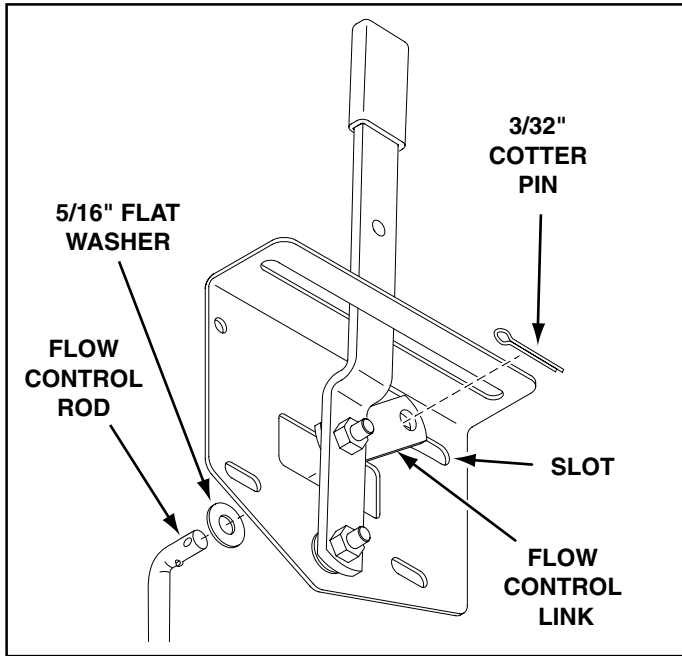

FIGURE 8

18. Hook the free end of the flow control rod through the hole in the slide gate bracket located near the bottom of the hopper. See figure 9.

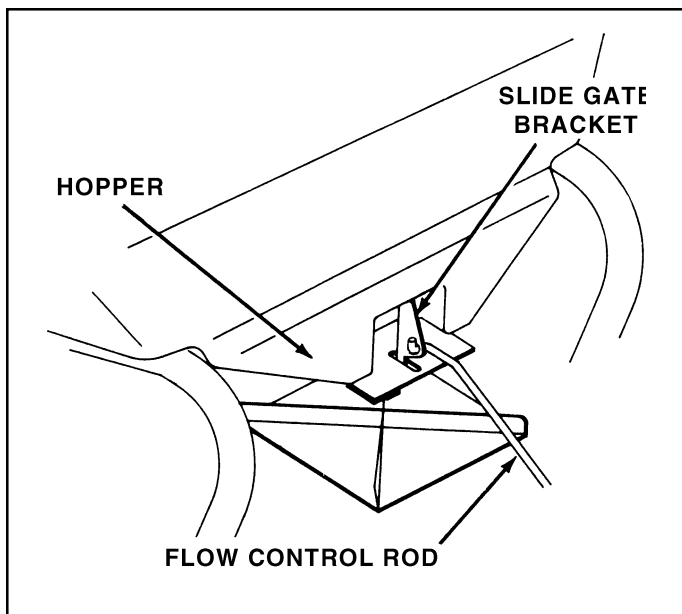

FIGURE 9

19. Assemble the flow control mounting bracket to the hitch tube using two 1/4" x 1-3/4" hex bolts, six 5/16" flat washers and two 1/4" hex lock nuts as shown in figure 10. Do not tighten at this time.

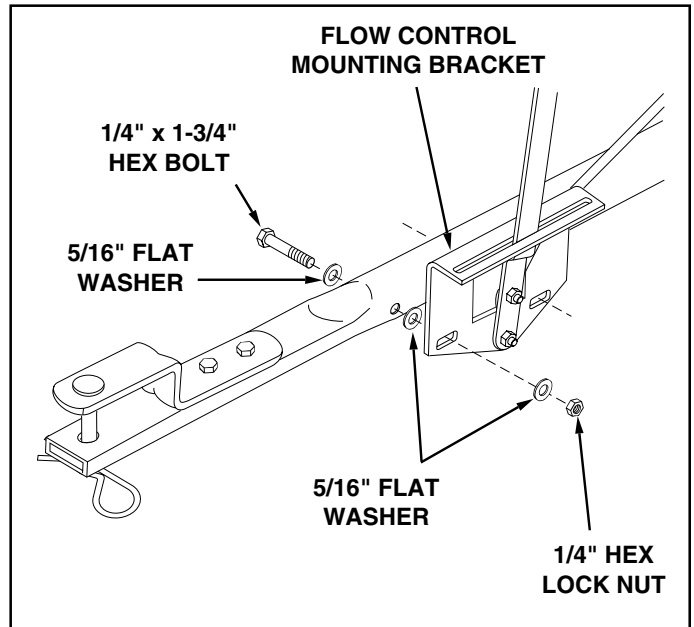

FIGURE 10

20. Place the adjustable stop into the "ON" end of the slot in the top of the flow control mounting bracket. Secure with the 1/4" x 3/4" carriage bolt, a nylon washer, a 5/16" flat washer and the nylon wing nut. See figure 11.

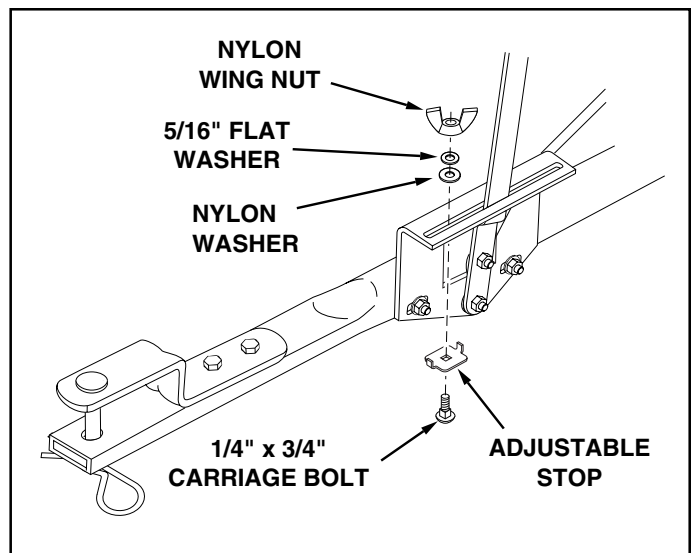

FIGURE 11

21. Position the flow control mounting bracket (figure 12).
  - a. Push on flow control arm until it locks in "OFF" position.
  - b. Slide flow control mounting bracket along tube until closure plate in bottom of hopper just closes.
  - c. Snug the 1/4" lock nuts just enough to hold flow control mounting bracket in place.
  - d. Set adjustable stop at "5". Pull flow control arm against stop. Verify that closure plate has opened about half way.
  - e. If closure plate does not open half way, it may be closed too far at "OFF". Adjust position of flow control mounting bracket until closure plate will open about half way at "5" and still close when arm is locked in "OFF". **Tighten 1/4" lock nuts.**

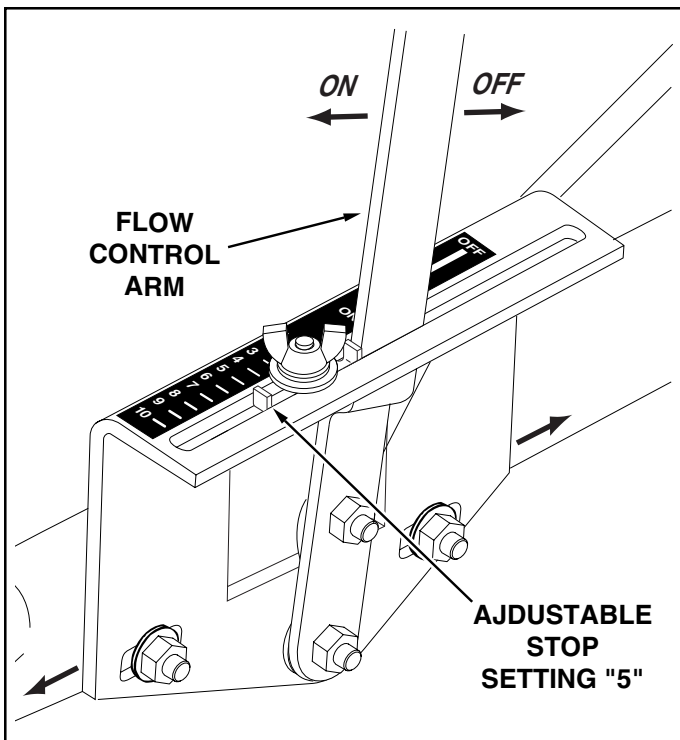

FIGURE 12

## OPERATION

### HOW TO USE YOUR SPREADER

#### SETTING THE FLOW CONTROL

(Refer to figure 12 on page 7.)

1. Loosen the nylon wing nut, set the adjustable stop to the desired flow rate setting and retighten the wing nut. The higher the setting number, the wider the opening in the bottom of the hopper.
2. Refer to the application chart on page 8 and to the instructions on the fertilizer bag to select the proper flow rate setting.
3. Pull the flow control arm against the adjustable stop for the on position and toward the hopper for the off position.

#### USING YOUR SPREADER

We do not recommend the use of any powdered lawn chemicals, due to difficulty in obtaining a satisfactory or consistent broadcast pattern.

1. Determine approximate square footage of area to be covered and estimate amount of material required.
2. Before filling the hopper make sure the flow control arm is in the off position and the closure plate is shut.
3. Break up any lumpy fertilizer as you fill the hopper.
4. Set the adjustable stop with the flow control arm still in the off position. Refer to the application chart on this page and to the instructions on the fertilizer bag to select the proper flow rate setting.
5. The application chart is calculated for light to heavy application at a vehicle speed of 3 mph, or 100 ft. in 23 seconds. A variation in speed will require an adjustment of the flow rate to maintain the same coverage. The faster you drive, the wider the broadcast width.
6. Always start the tractor in motion before opening closure plate.
7. Always shut the closure plate before turning or stopping the tractor.
8. If fertilizer is accidentally deposited too heavily in a small area, soak the area thoroughly with a garden hose or sprinkler to prevent burning of the lawn.
9. To insure uniform coverage, make each pass so that the broadcast pattern slightly overlaps the pattern from the previous pass as shown in figure 13. The approximate broadcast widths for different materials are shown in the application chart on this page.
10. When broadcasting weed control fertilizers, make sure the broadcast pattern does not hit evergreen trees, flowers or shrubs.
11. Heavy moisture conditions may require a cover over the hopper to keep contents dry. The vinyl cover (available as an accessory) acts as a wind and moisture shield, but should not be used as a rain cover. Refer to the parts list on page 11.

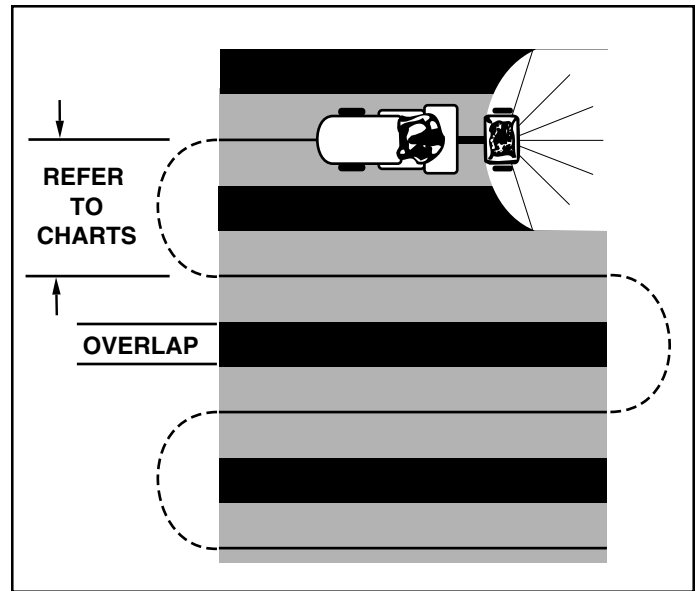

FIGURE 13

**IMPORTANT:** Application rates shown in the chart are affected by humidity and by the moisture content of the material (granular and pellet). Some minor setting adjustments may be necessary to compensate for this condition.

APPLICATION CHART (SHIELD UP)		
TYPE MATERIAL	FLOW SETTING	SPREAD WIDTH
FERTILIZER		
Powder	3 - 5	3' - 4'
Granular	3 - 5	8' - 10'
Pelleted	3 - 5	10' - 12'
Organic	6 - 8	6' - 8'
GRASS SEED		
Fine	3 - 4	6' - 7'
Coarse	4 - 5	8' - 9'
ICE MELTER	6 - 8	10' - 12'

**OPERATING SPEED - 3 MPH. (100 ft. in 23 seconds)**



## MAINTENANCE

### CHECK FOR LOOSE FASTENERS

1. Before each use make a thorough visual check of the spreader for any bolts and nuts which may have loosened. Retighten any loose bolts and nuts.

### CHECK FOR WORN OR DAMAGED PARTS

2. Check for worn or damaged parts before each use. Repair or replace parts if necessary.

### CHECK TIRE INFLATION

3. Check if tires are adequately inflated before each use. Do not inflate beyond maximum recommended pressure.



**CAUTION: DO NOT** inflate tires beyond the maximum recommended pressure printed on side of tire.

### CLEANING

4. Rinse inside of hopper and exterior of spreader and dry off before storing.

### LUBRICATE (See figure 14.)

5. Lightly apply automotive grease as needed to the sprocket and gear.
6. Oil the nylon bushings on the vertical sprocket shaft and on the axle at least once a year, or more often as needed.
7. Oil right hand (idler) wheel bearing at least once a year or more often as needed.

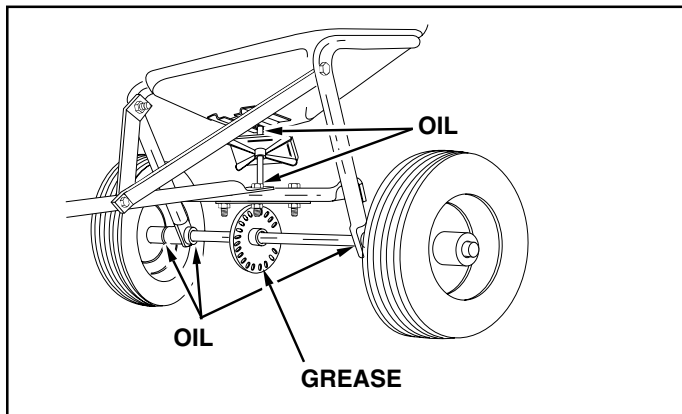

FIGURE 14

## STORAGE

1. Rinse inside of hopper and exterior of spreader and dry off before storing.
2. Store in a clean, dry area.

## SERVICE AND ADJUSTMENTS

1. If the axle, slotted gear and sprocket assembly is disassembled, mark down the positions of the parts as they are removed. The drive wheel and sprocket positions in relation to the slotted gear determine which direction the spreader plate will spin. Be sure to reassemble them in their original positions. (Refer to figure 4 on page 5.) Use shim washers (Ref. no. 21 on pages 10 and 11) as needed for minimum backlash. Add grease to gear and sprocket.
2. If the agitator wire becomes damaged or worn it can be replaced. Loosen the 3/8" hex nut on top of sprocket shaft until agitator wire is free. Remove old agitator wire from hole in agitator sleeve and replace with new agitator wire. Position agitator wire so that sprocket shaft turns freely, then tighten 3/8" hex nut on top of sprocket shaft. See figure 15.

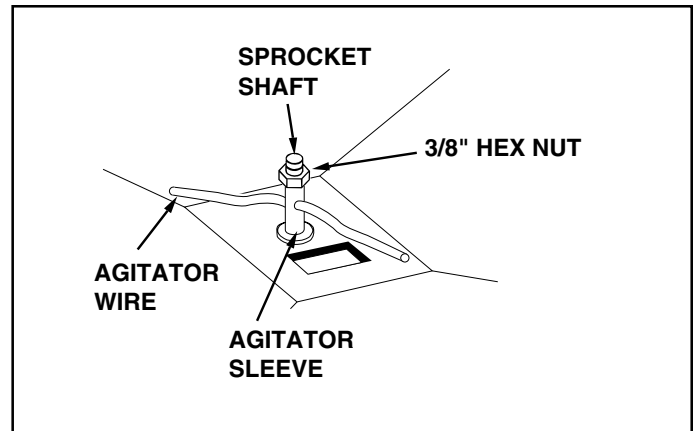
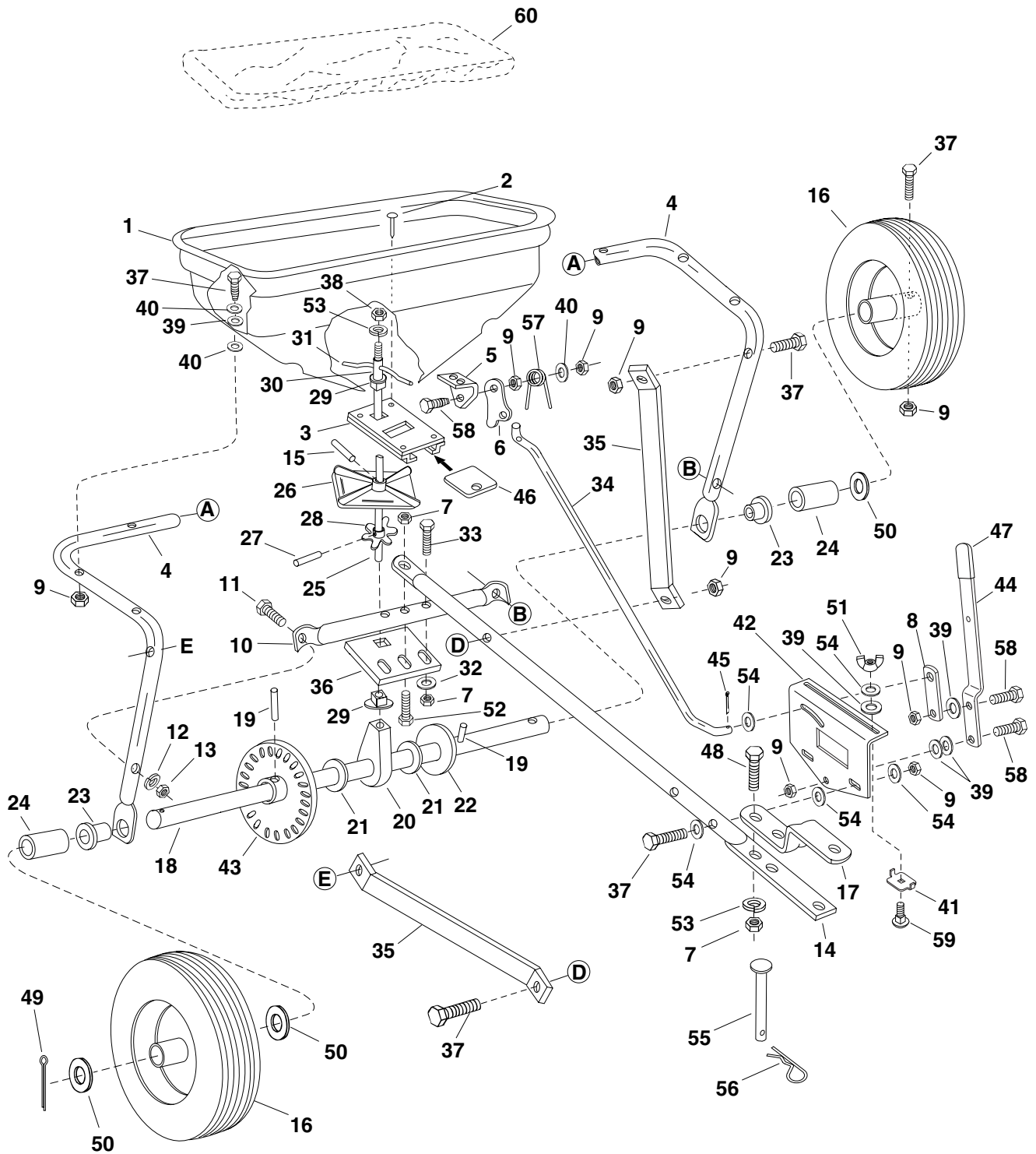

FIGURE 15

REPAIR PARTS FOR BROADCAST SPREADER MODEL 45-02113



**REPAIR PARTS FOR BROADCAST SPREADER MODEL 45-02113**

REF. NO.	PART NO.	QTY.	DESCRIPTION	REF. NO.	PART NO.	QTY.	DESCRIPTION
1	44466	1	Hopper	32	43070	5	Washer, Flat 3/8" *
2	43882	4	Rivet, Stainless	33	41576	2	Bolt, Hex 3/8-16 x 1-3/4" Lg.*
3	62482	1	Ass'y, Guide Closure	34	44469	1	Rod, Flow Control
4	44462	1	Tube, Frame	35	23525	2	Brace, Hitch
5	23753	1	Slide Gate Angle Bracket	36	23762	1	Shaft Support Plate
6	23758	1	Slide Gate Bracket	37	1509-069	12	Bolt, Hex 1/4-20 x 1-3/4"
7	43082	5	Nut, Hex Lock 3/8-16 Thd.*	38	43015	1	Nut, Hex 3/8-16
8	24857	1	Flow Control Link	39	1543-069	10	Washer, Nylon
9	43013	16	Nut, Hex Lock 1/4-20 Thd.*	40	43088	13	Washer, Flat 1/4" Std.
10	43808	1	Tube, Crossover	41	24858	1	Stop, Adjustable
11	43084	2	Bolt, Hex 5/16-18 x 1-3/4" Lg.	42	24855	1	Bracket, Flow Control Mount
12	43086	2	Lock Washer, 5/16"	43	62474	1	Gear Assembly
13	43064	2	Nut, Hex Lock, 5/16-18 Thd.*	44	24859	1	Flow Control Arm
14	44487	1	Tube, Hitch	45	44101	1	Cotter Pin 3/32" x 3/4" Lg.*
15	46055	1	Pin, Spring 1/8" Dia. x 1" Lg.	46	23533	1	Plate, Closure
16	44457	2	Wheel, Drive	47	43848	1	Grip, Flow Control Arm
17	23687	1	Bracket, Hitch	48	43087	2	Bolt, Hex 3/8-16 x 1-1/4" Lg.*
18	25017	1	Shaft, Axle	49	43093	1	Pin, Cotter 1/8" x 1-1/2"
19	43851	2	Pin, Spring 3/16" Dia. x 1-1/4" Lg.	50	43009	4	Washer, Flat 1-5/8" O.D.
20	43871	1	Bushing, Axle Shaft	51	47141	1	Wing Nut, Nylon
21	1540-032	5	Washer, Flat .78 I.D.	52	43054	1	Bolt, Hex 3/8-16 x 2" Lg.*
22	1540-162	1	Washer, Flat 1/2"	53	43003	4	Lock Washer, 3/8" *
23	47615	2	Bearing, Flange	54	R19111116	8	Washer, 5/16 SAE
24	48665	2	Tube, Spacer	55	47623	1	Hitch Pin
25	23524	1	Shaft, Sprocket	56	43343	1	Hair Cotter Pin, 1/8"
26	04367	1	Spreader Plate	57	44566	1	Spring, Torsion
27	43850	1	Pin, Spring 1/8" Dia. x 5/8".	58	43012	3	Bolt, Hex 1/4-20 x 3/4" Lg.*
28	44468	1	Sprocket, 6 Tooth	59	44950	1	Bolt, Carriage 1/4-20 x 3/4"
29	44285	2	Bushing, Delrin	60	43962	1	Vinyl Cover (Optional)
30	23766	1	Sleeve, Agitator		48668	1	Owner's Manual
31	43878	1	Wire, Agitator				

\*Purchase common hardware locally.

For Agri Fab Discount Parts Call 606-678-9623 or 606-561-4983

**REPAIR PARTS**

Agri-Fab, Inc.  
303 West Raymond  
Sullivan, IL. 61951  
217-728-8388  
[www.agri-fab.com](http://www.agri-fab.com)

[www.mymowerparts.com](http://www.mymowerparts.com)